

**SWAGBOARD®**  
ELECTRIC SKATEBOARD

SPECTRA  
*MINI*

Quick Start Guide

# Meet the Spectra Mini

Follow along with this guide to get to know your board better. Let's roll!



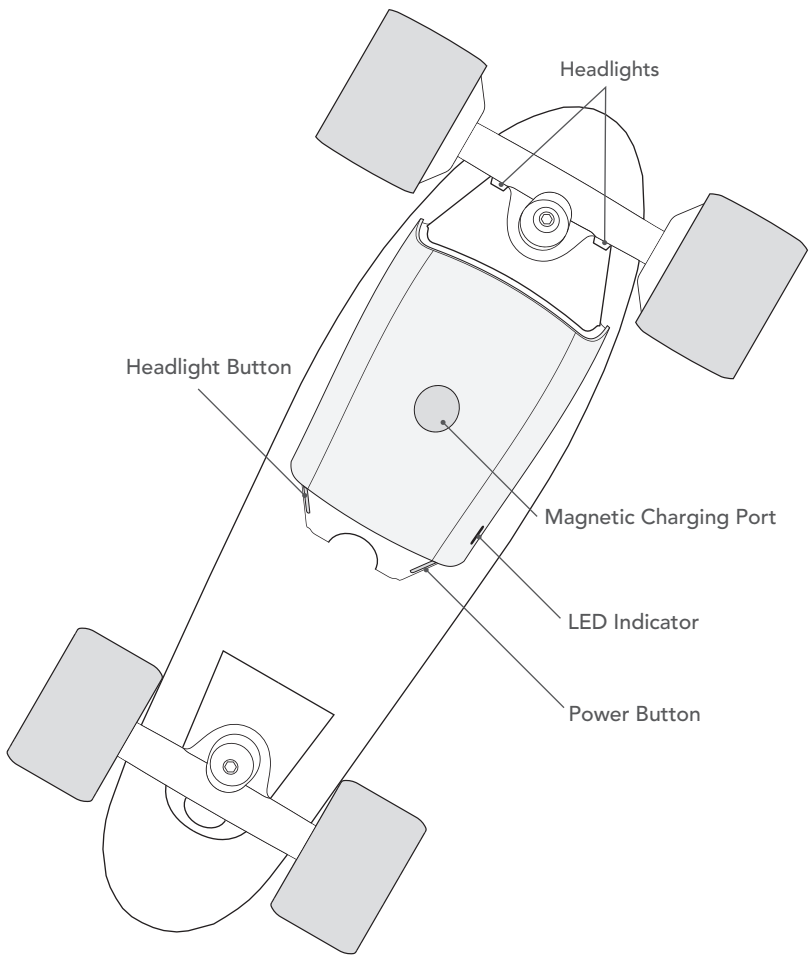

Headlights

Headlight Button

Magnetic Charging Port

LED Indicator

Power Button

## 01 Download the App

- Search for **eBoard GO** in the App or Play Store and install the app.
- Turn on your phone's Bluetooth function then sign up or log into the app with your account.
- Connect to your board via the app. For help, visit our website or contact customer service.



## 02 Check the Battery Level

Press and hold the Power Button for two seconds to turn the board on. The LED Indicator will turn on and the board will emit a beeping sound.

- Check the LED Indicator color to see battery life.

Blue/Green (100% ~ 20%)  
Yellow (20% ~ 5%)  
Red (5% ~ 1%)

- Check the app to see precise battery life and remaining ride time.

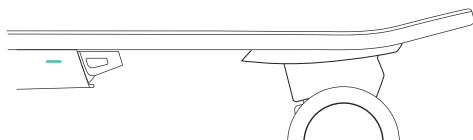

## 03 Charge the Board

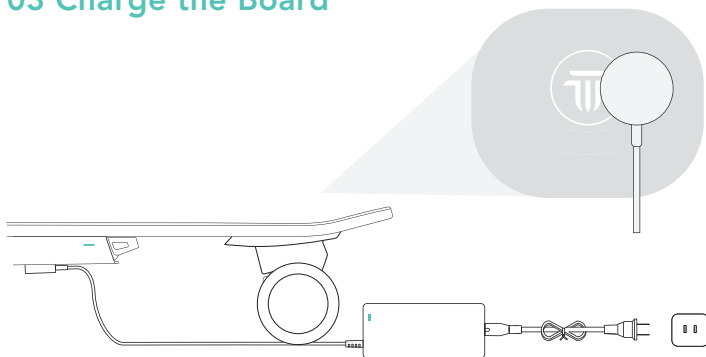

Plug the charger into a power source and connect the end to the magnetic charging port. The charger's light turns red during charging. It will turn green to indicate a full charge.

## 04 Learn About the SenDeck

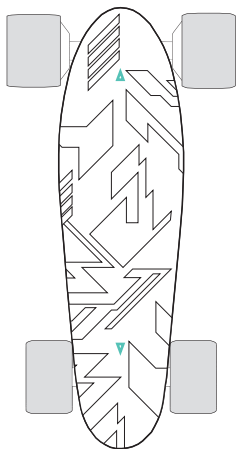

### SENSORS

There are two sensor areas on the SenDeck of SPECTRA Mini.

Your feet should press on each  arrow.

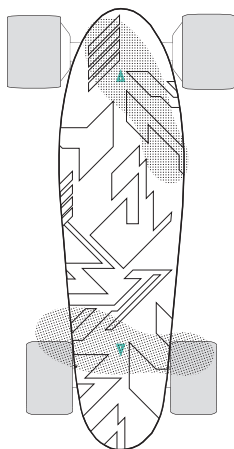
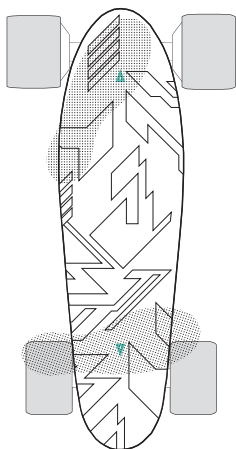

The Spectra is compatible with different stances. Ride the way you want!

## 05 Ride Spectra

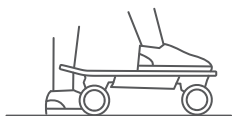

### 1. Step On

First, check section 04 for standing postures. Step on the deck with your front foot then step on with your rear foot.

Beeping Pattern: ●



### 2. Stand Up Straight

Keep your body relatively straight with your knees slightly bent. Try to maintain balance and keep the deck level.

Beeping Pattern: ● ●



### 3. Move Forward

Lean your body slightly forward. The Spectra will speed up gradually.



### 4. Lean to Make Turns

To turn left/right, lean your body left/right. Tilt the deck to steer more easily.

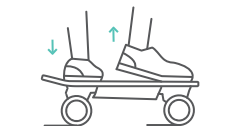

### 5. Slow Down & Brake

Lean your body slightly backwards to slow to a stop. Lift your front heel to further reduce acceleration and slow down more quickly.

Beeping Pattern: ● ● ● ● ● ● ● ●

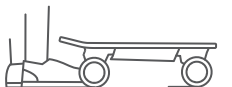

### 6. Step Off to Stop Instantly

Jump off the side of the board or rapidly tap with your rear foot to slow down and stop quickly.

Beeping Pattern: 

**Note:** Exercise caution when jumping off the board. Do not do this if you are not familiar with this maneuver.

## 06 Specifications

<b>Model</b>	Spectra Mini
<b>Size</b>	23 x 10 x 5.5 in
<b>Weight</b>	9 lbs
<b>Motor</b>	200 W x 1
<b>Range*</b>	5.0 ~ 5.6 miles
<b>Max. Speed*</b>	9.3 mph
<b>Max. Slope*</b>	7° uphill / 5° downhill
<b>Battery</b>	19.2 V, 1500 mAh, 29.76 Wh
<b>Recharging Time</b>	Approx. 22 ~ 30 min.
<b>Max. Load</b>	180 lbs

\*Actual Range, Max. Speed and Max. Slope may vary depending on rider weight, outdoor temperatures, terrain, and other environmental factors.

## 07 Adjusting the Trucks

Use the provided tool to loosen the trucks if desired. Loosening them slightly will allow to the deck to tilt more easily which may aid in turning.



**Note:** The trucks cannot be dissembled.

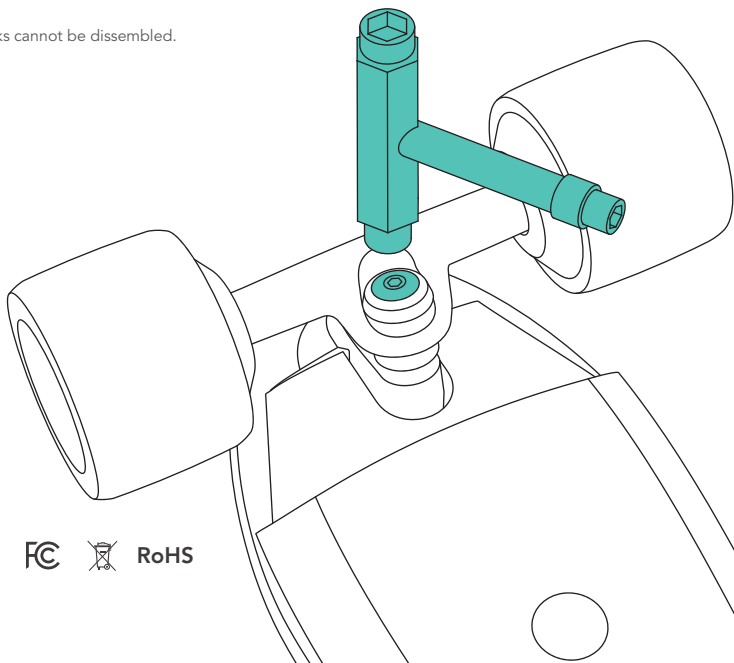

# SWAGBOARD®

Copyright © 2017 SWAGTRON. All rights reserved.

\*Google Play and the Google Play logo are trademarks of Google Inc.

\*Apple and the Apple logo are trademarks of Apple Inc., registered in the U.S. and other countries. App Store is a service mark of Apple Inc., registered in the U.S. and other countries.